

C5 series package: 1700V 450A IGBT module

[Datasheet](#)

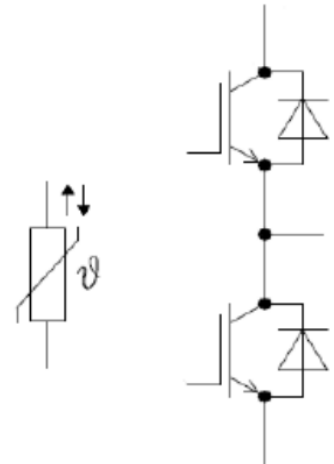

Equivalent
Circuit Schematic

Features:

- $V_{CES} = 1700V$
- $I_C \text{ nom} = 450A$
- Trenchgate Gen.7 IGBT technology
- $V_{CE(sat)}$ with positive temperature coefficient
- High RBSOA capability
- Low static losses: $V_{CE(sat)} = 1,55V@25C$

Options:

- pre-applied TIM (option +M01)
- adoption for parallel connection (Vf selection)

Typical Applications:

- Motor Drives
- Solar Applications
- UPS Systems
- Energy Storage

**IGBT, Inverter / IGBT
Maximum Rated Values**

Collector-emitter Voltage	$T_{vj} = 25^{\circ}\text{C}$	V_{CES}	1700	V
Implemented collector current		I_{Cnom}	450	A
Continuous DC Collector Current	$T_C = 90^{\circ}\text{C}, T_{vj\ max} = 175^{\circ}\text{C}$	I_C	450	A
Repetitive Peak Collector Current	$t_p\ T_{vj\ op}$	I_{CRM}	900	A
Gate-emitter Peak Voltage		V_{GES}	± 20	V

Characteristic Values
min. typ. max.

Collector-emitter Saturation Voltage ¹⁾	$I_C = 450\text{A}, V_{GE} = 15\text{V}$	$T_{vj} = 25^{\circ}\text{C}$ $T_{vj} = 125^{\circ}\text{C}$ $T_{vj} = 150^{\circ}\text{C}$ $T_{vj} = 175^{\circ}\text{C}$	V_{CEsat}	-	1.55 1.75 1.80 1.87	-	V
Gate Threshold Voltage	$V_{CE} = V_{GE}, I_C = 9\text{mA}, T_{vj} = 25^{\circ}\text{C}$		V_{GEth}	-	6.10	-	V
Gate Charge	$V_{GE} = -15\text{V}/15\text{V}, V_{CE} = 600\text{V}$		Q_G	-	4.2	-	μC
Internal Gate Resistor	$T_{vj} = 25^{\circ}\text{C}$		R_{Gint}	-	0.43	-	Ω
Input Capacitance	$f = 100\text{kHz}, T_{vj} = 25^{\circ}\text{C}, V_{CE} = 25\text{V}, V_{GE} = 0\text{V}$		C_{ies}	-	45.9	-	nF
Reverse Transfer Capacitance	$f = 100\text{kHz}, T_{vj} = 25^{\circ}\text{C}, V_{CE} = 25\text{V}, V_{GE} = 0\text{V}$		C_{res}	-	0.16	-	nF
Collector-emitter Cutoff Current	$V_{CE} = 1700\text{V}, V_{GE} = 0\text{V}, T_{vj} = 25^{\circ}\text{C}$		I_{CES}	-	-	1	mA
Gate-emitter Leakage Current	$V_{CE} = 0\text{V}, V_{GE} = 20\text{V}, T_{vj} = 25^{\circ}\text{C}$		I_{GES}	-	-	100	nA
Turn-on Delay Time, Inductive Load	$I_C = 450\text{A}, V_{CE} = 900\text{V}$ $V_{GE} = -8\text{V}/15\text{V}$ $R_{GON} = 1.5\Omega$	$T_{vj} = 25^{\circ}\text{C}$ $T_{vj} = 125^{\circ}\text{C}$ $T_{vj} = 150^{\circ}\text{C}$ $T_{vj} = 175^{\circ}\text{C}$	t_{don}	-	142 148 149 150	-	ns
Rise Time, Inductive Load	$I_C = 450\text{A}, V_{CE} = 900\text{V}$ $V_{GE} = -8\text{V}/15\text{V}$ $R_{GON} = 1.5\Omega$	$T_{vj} = 25^{\circ}\text{C}$ $T_{vj} = 125^{\circ}\text{C}$ $T_{vj} = 150^{\circ}\text{C}$ $T_{vj} = 175^{\circ}\text{C}$	t_r	-	52 64 65 67	-	ns
Turn-off Delay Time, Inductive Load	$I_C = 450\text{A}, V_{CE} = 900\text{V}$ $V_{GE} = -8\text{V}/15\text{V}$ $R_{Goff} = 1.5\Omega$	$T_{vj} = 25^{\circ}\text{C}$ $T_{vj} = 125^{\circ}\text{C}$ $T_{vj} = 150^{\circ}\text{C}$ $T_{vj} = 175^{\circ}\text{C}$	t_{doff}	-	499 540 549 560	-	ns
Fall Time, Inductive Load	$I_C = 450\text{A}, V_{CE} = 900\text{V}$ $V_{GE} = -8\text{V}/15\text{V}$ $R_{Goff} = 1.5\Omega$	$T_{vj} = 25^{\circ}\text{C}$ $T_{vj} = 125^{\circ}\text{C}$ $T_{vj} = 150^{\circ}\text{C}$ $T_{vj} = 175^{\circ}\text{C}$	t_f	-	449 733 783 870	-	ns
Turn-on Energy Loss per Pulse	$I_C = 450\text{A}, V_{CE} = 900\text{V}, L_{\sigma} = 30\text{nH}$ $V_{GE} = -8\text{V}/15\text{V}, R_{GON} = 1.5\Omega$ $di/dt = 5448 (T_{vj} = 175^{\circ}\text{C})$	$T_{vj} = 25^{\circ}\text{C}$ $T_{vj} = 125^{\circ}\text{C}$ $T_{vj} = 150^{\circ}\text{C}$ $T_{vj} = 175^{\circ}\text{C}$	E_{on}	-	107 145 156 165	-	mJ
Turn-off energy Loss per Pulse	$I_C = 450\text{A}, V_{CE} = 900\text{V}, L_{\sigma} = 30\text{nH}$ $V_{GE} = 1-8\text{V}/15\text{V}, R_{Goff} = 1/5\Omega$ $du/dt = 4762 (T_{vj} = 175^{\circ}\text{C})$	$T_{vj} = 25^{\circ}\text{C}$ $T_{vj} = 125^{\circ}\text{C}$ $T_{vj} = 150^{\circ}\text{C}$ $T_{vj} = 175^{\circ}\text{C}$	E_{off}	-	112 155 167 175	-	mJ
SC Data	$V_{GE} = -8\text{V}/15\text{V}$ $V_{CC} = 1000\text{V}$	$t_p \leq 8\mu\text{s}, T_{vj} = 150^{\circ}\text{C}$ $t_p \leq 6\mu\text{s}, T_{vj} = 175^{\circ}\text{C}$	I_{sc}	-	1900 1800	-	A

Thermal Resistance, Junction to Case	Per IGBT	R _{thJC}	-	0.060	-	K/W
Thermal Resistance, Case to Heatsink	Per IGBT $\lambda_{grease} = 1W/(m \cdot K)$	R _{thCH}	-	0.035	-	K/W
Temperature under Switching Conditions		T _{vj op}	-40		175	°C

Diode, Inverter Maximum Rated Values

Repetitive Peak Reverse Voltage	T _{vj} = 25°C	V _{RRM}		1700		V
Continuous DC Forward Current		I _{Fnom}		450		A
Repetitive Peak Forward Current	t _p = 1ms	I _{FRM}		900		A

Characteristic Values

			min. typ. max.				
Forward Voltage ¹⁾	I _F = 450A, V _{GE} = 0V	T _{vj} = 25°C T _{vj} = 125°C T _{vj} = 150°C T _{vj} = 175°C	V _F	-	1.65 1.92 2.00 2.05	-	V
Peak Reverse Recovery Current	I _F = 450A, V _R = 900V -di _F /dt = 5556A/us (T _{vj} = 175°C) V _{GE} = -8V	T _{vj} = 25°C T _{vj} = 125°C T _{vj} = 150°C T _{vj} = 175°C	I _{RM}	-	662 678 686 678	-	A
Recovery Charge	I _F = 450A, V _R = 900V -di _F /dt = 5556A/us (T _{vj} = 175°C) V _{GE} = -8V	T _{vj} = 25°C T _{vj} = 125°C T _{vj} = 150°C T _{vj} = 175°C	Q _R	-	79 114 125 135	-	μC
Reverse Recovery Energy	I _F = 450A, V _R = 900V -di _F /dt = 5556A/us (T _{vj} = 175°C) V _{GE} = -8V	T _{vj} = 25°C T _{vj} = 125°C T _{vj} = 150°C T _{vj} = 175°C	E _{rec}	-	36 59 66 71	-	mJ
Thermal Resistance, Junction to Case	Per FRD		R _{thJC}	-	0.078	-	K/W
Thermal Resistance, Case to Heatsink	Per FRD $\lambda_{grease} = 1W/(m \cdot K)$		R _{thCH}	-	0.039	-	K/W
Temperature under Switching Conditions			T _{vj op}	-40	-	175	°C

NTC-Thermistor / NTC Maximum Rated Values

			min. typ. max.				
Rated Resistance	T _{NTC} = 25°C		R ₂₅	-	5	-	KΩ
Deviation of R100 R100	T _{NTC} = 100°C, R ₁₀₀ = 465Ω		ΔR/R	-5	-	5	%
Power Dissipation	T _{NTC} = 25°C		P ₂₅	-	-	20	mW
B-Value B	R ₂ = R ₂₅ exp[B _{25/50} (1/T ₂ -1/(298.15K))]		B _{25/50}	-	3375	-	K
	R ₂ = R ₂₅ exp[B _{25/80} (1/T ₂ -1/(298.15K))]		B _{25/80}	-	3414	-	K
	R ₂ = R ₂₅ exp[B _{25/100} (1/T ₂ -1/(298.15K))]		B _{25/100}	-	3436	-	K

1) Terminal impedance is not included.

Module

Isolation Test Voltage	RMS, f=50Hz, t=1min	VISOL	3.4	kV
Isolation Test Voltage of NTC	RMS, f=50Hz, t=1min	VISOL(NTC)	3.4	kV
Material of Module Baseplate			Cu	
Internal Isolation			ZTA	
Creepage Distance	Terminal to heatsink, min Terminal to terminal, min		15 12.1	mm
Clearance	Terminal to heatsink, min Terminal to terminal, min		12.5 10	mm
Comparative Tracking Index		CTI	>200	

min. typ. max.

Stray Inductance Module		L _{sCE}	-	20	-	nH
Module Lead Resistance, Terminals-Chip	T _C = 25°C, Per Switch	R _{CC'+EE'}	-	0.8	-	mΩ
Thermal Resistance, Case to Heatsink	including thermal coupling, Ts underneath module (Agrease=0.81 W/(m*K))	R _{thCH}	-	0.014	-	K/W
Storage Temperature		T _{stg}	-40	-	125	°C
Mounting Torque for Module Mounting	Screw M5 / M5	M	3.0	-	6.0	Nm
Mounting Torque for Terminal Mounting	Screw M6 / M6	M	3.0	-	6.0	Nm
Weight		G	-	345	-	g

Circuit Diagram

Output characteristic IGBT, Inverter (typical),
Inclusive RCC+EE' $I_c = f(V_{CE}), V_{GE} = 15V$

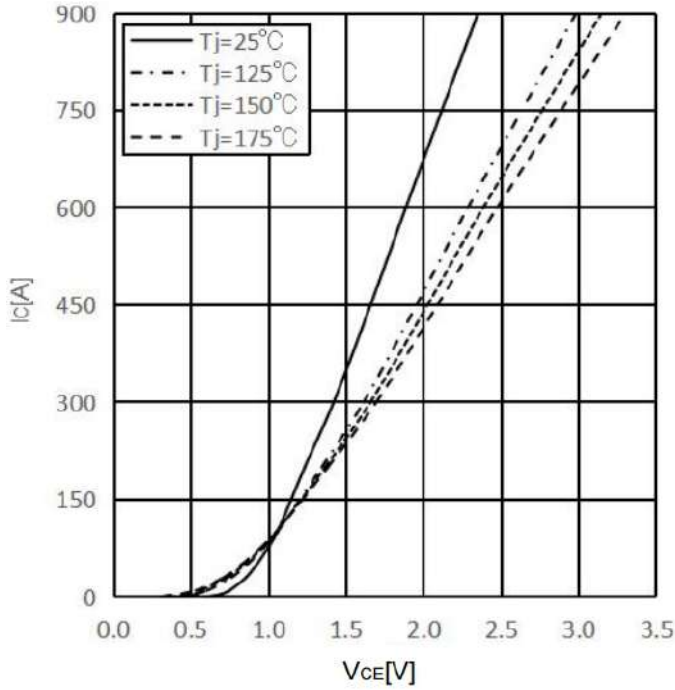

Output characteristic IGBT, Inverter (typical),
Inclusive RCC+EE' $I_c = f(V_{CE}), T_{vj} = 175^\circ C$

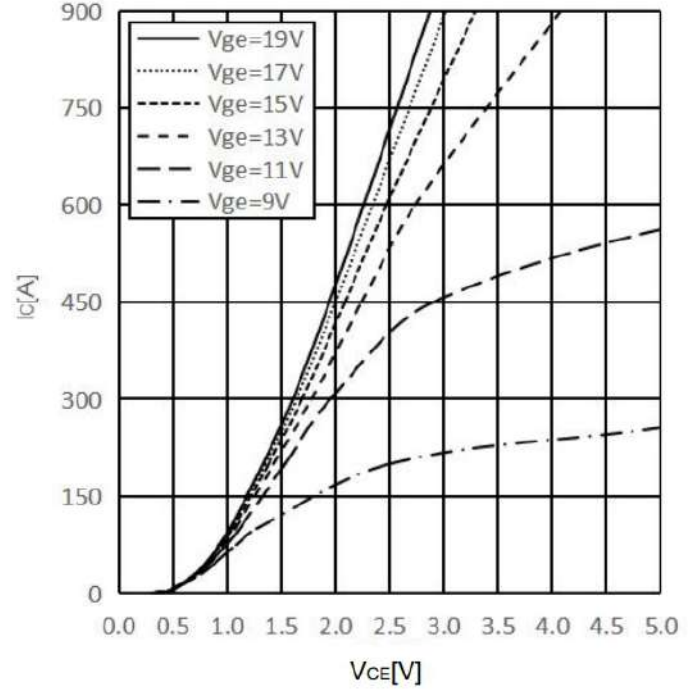

Transfer characteristic IGBT, Inverter (typical),
Inclusive RCC+EE' $I_c = f(V_{GE}), V_{CE} = 20V$

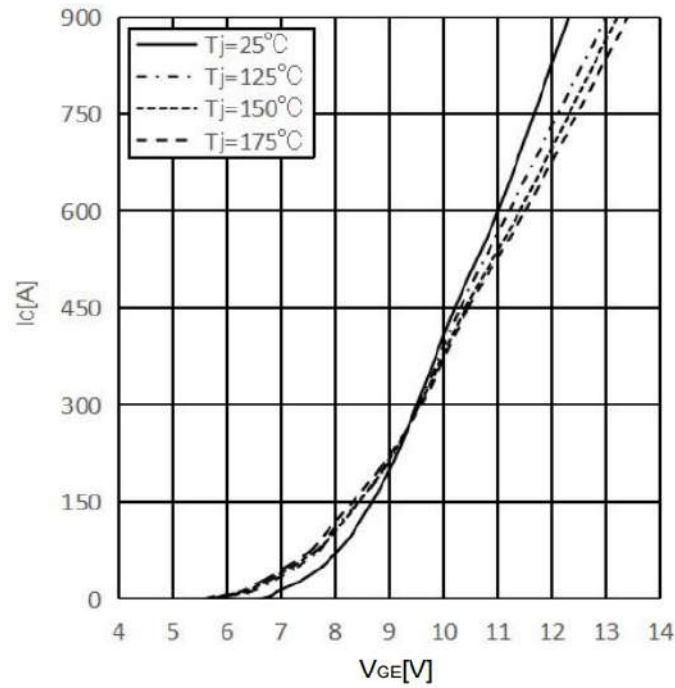

Switching losses IGBT, Inverter (Typical),
Inclusive RCC+EE' $E = f(I_c)$

$V_{GE} = +15V/-8V, R_{Gon} = 1.5\Omega, R_{Goff} = 1.5\Omega, V_{CC} = 600V$

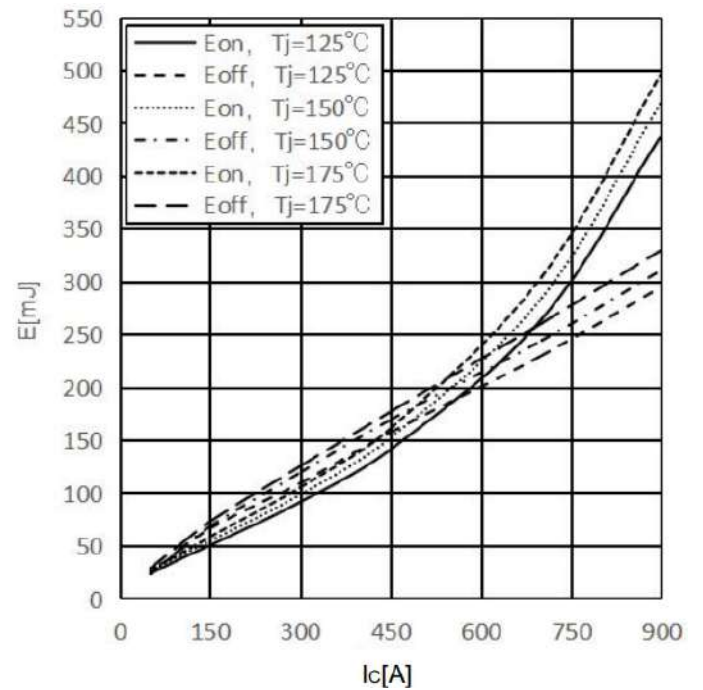

Switching losses IGBT, Inverter (Typical), Inclusive $R_{CC}+E_{E'}$
 $E = f(R_G)$
 $V_{GE} = +15V/-8V, I_C = 450A, V_{CE} = 900V$

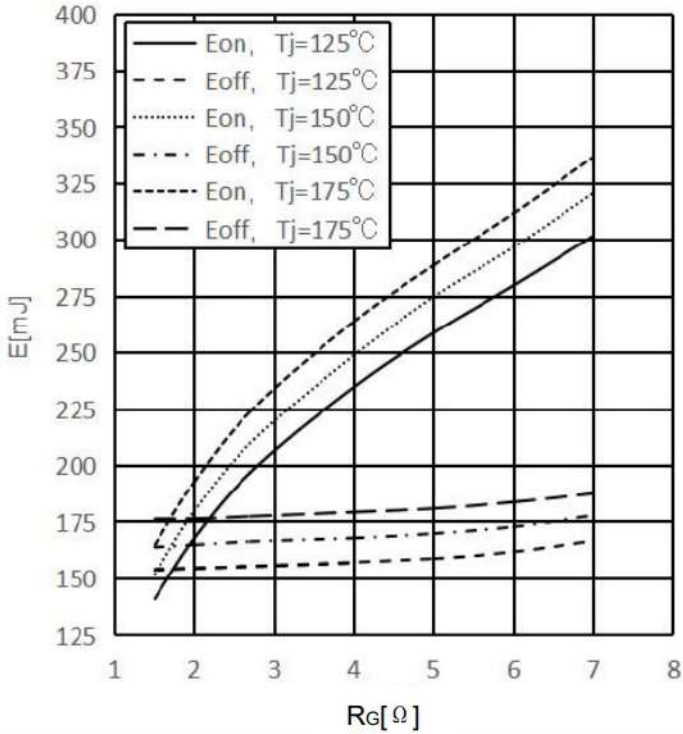

Switching times IGBT, Inverter (typical) IGBT
 $t_{don} = f(I_C), t_r = f(I_C), V_{GE} = +15V/-8V, V_{CE} = 900V$
 $R_{gon} = 1.5\Omega, R_{Goff} = 5\Omega, T_j = 175^\circ C$

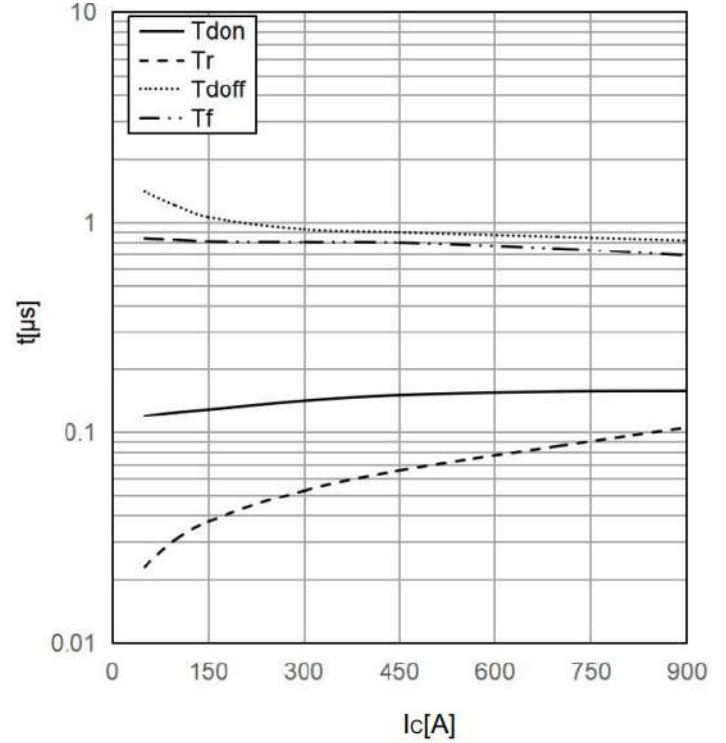

Switching times IGBT, Inverter (typical) IGBT
 $t_{don} = f(R_G), t_r = f(R_G), V_{GE} = +15V/-8V,$
 $I_C = 450A, V_{CE} = 900V, T_j = 175^\circ C$

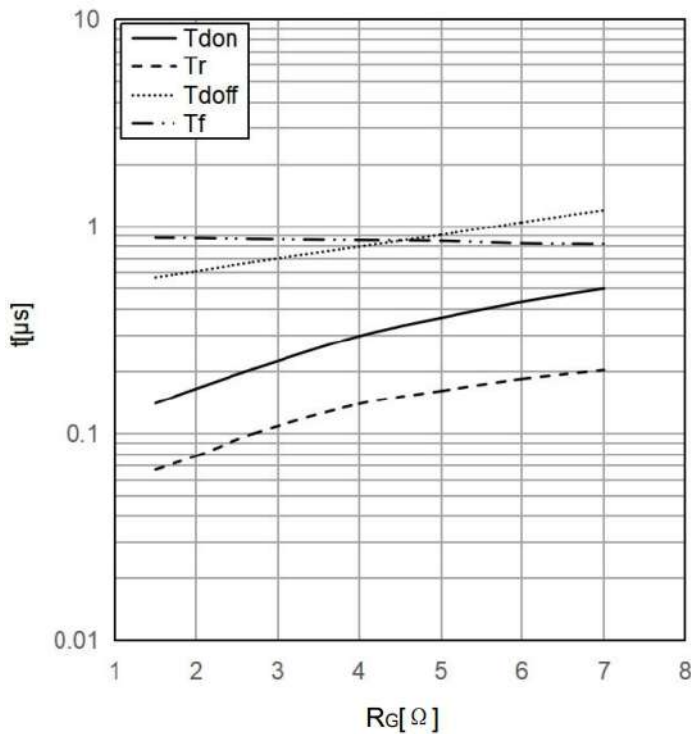

Inverter (typical) IGBT
 $dv/dt = f(R_G), V_{GE} = +15V/-8V$
 $I_C = 450A, V_{CE} = 900V, T_j = 25^\circ C$

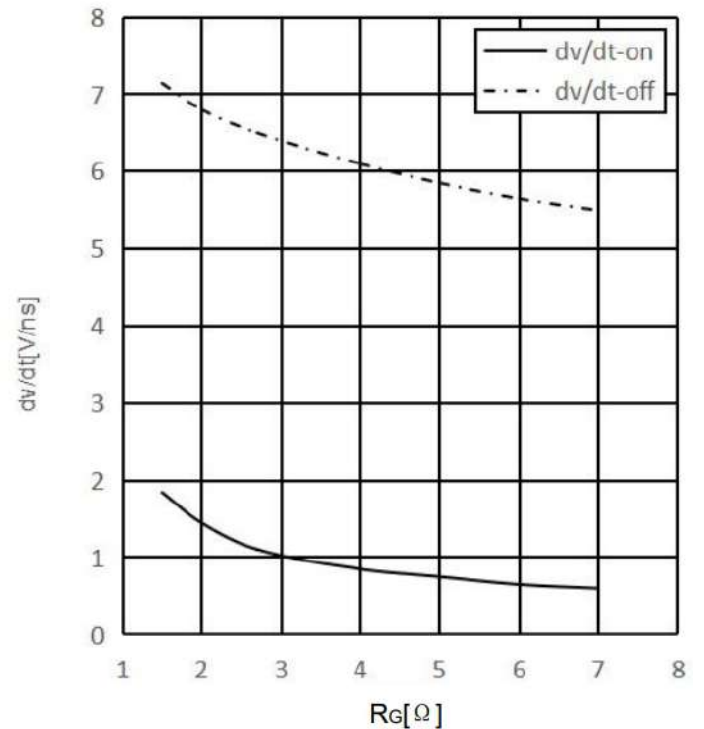

Transient thermal impedance IGBT, Inverter
 $Z_{thJC} = f(t)$

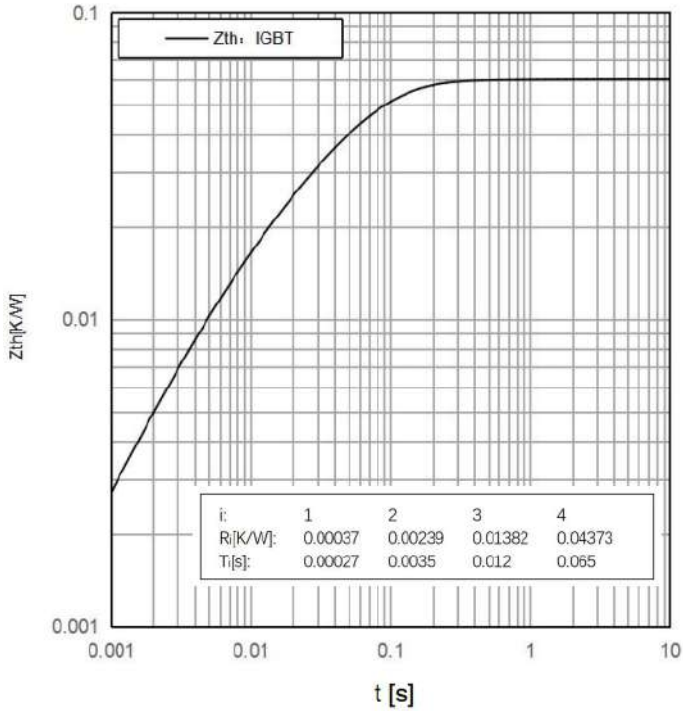

Reverse bias safe operating area IGBT,
 Inverter(RBSOA) $I_c = f(V_{CE})$
 $V_{GE} = +15V/-8V, R_{goff} = 5\Omega, T_{vj} = 175^\circ C$

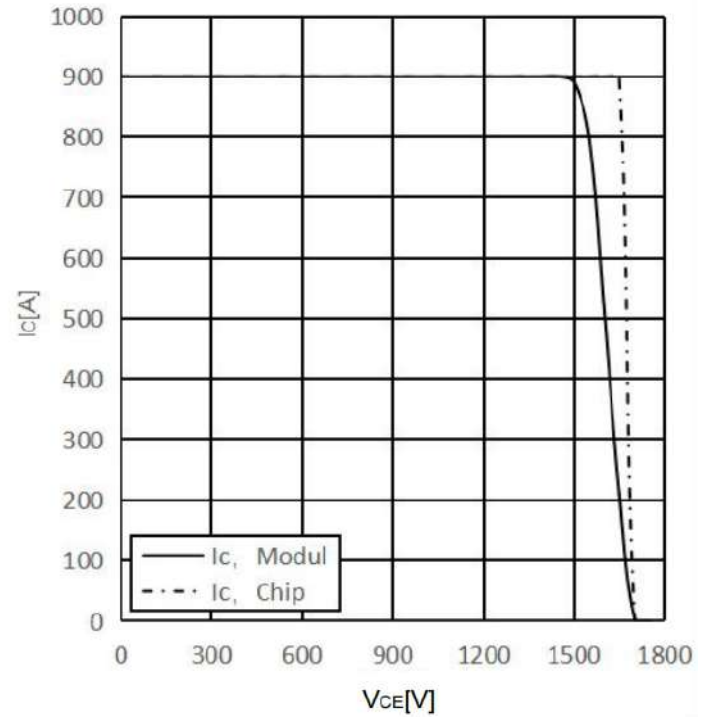

Forward characteristic FRD, Inverter (typical)
 $I_F = f(V_F)$

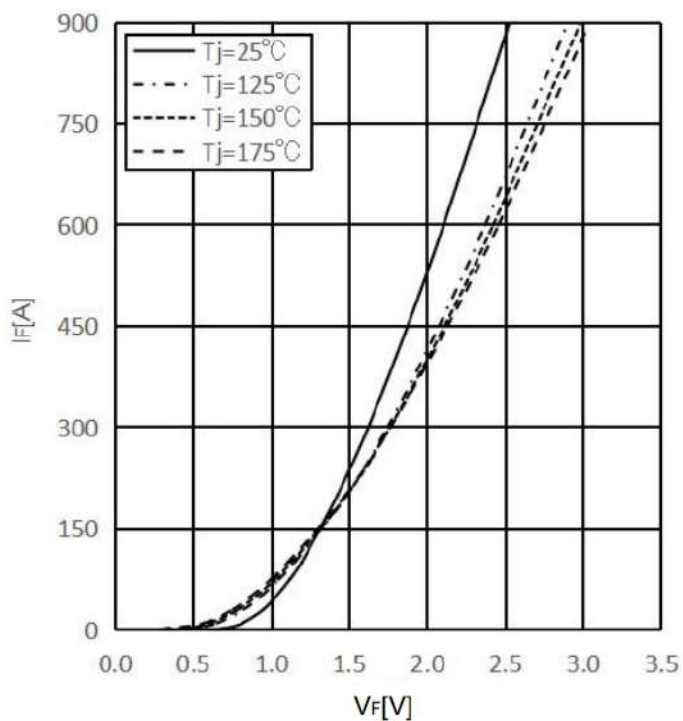

Switching Losses FRD, Inverter (typical),
 Inclusive $R_{CC} + EE'$
 $E_{rec} = f(I_F), R_{Gon} = 1.5\Omega, V_{CE} = 900V$

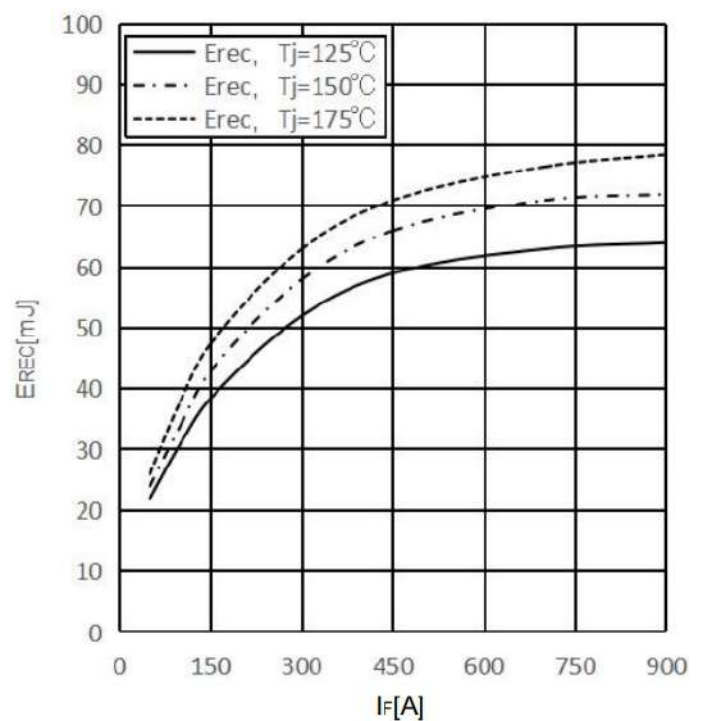

Switching Losses FRD, Inverter (typical),
Inclusive RCC'+EE'

$E_{rec} = f(R_g)$

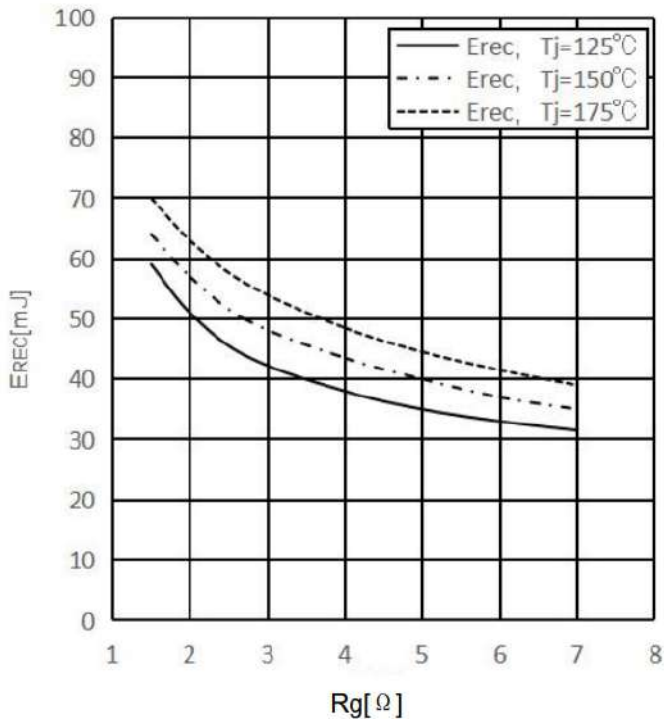

Transient thermal impedance IGBT, Inverter
 $Z_{thJC} = f(t)$

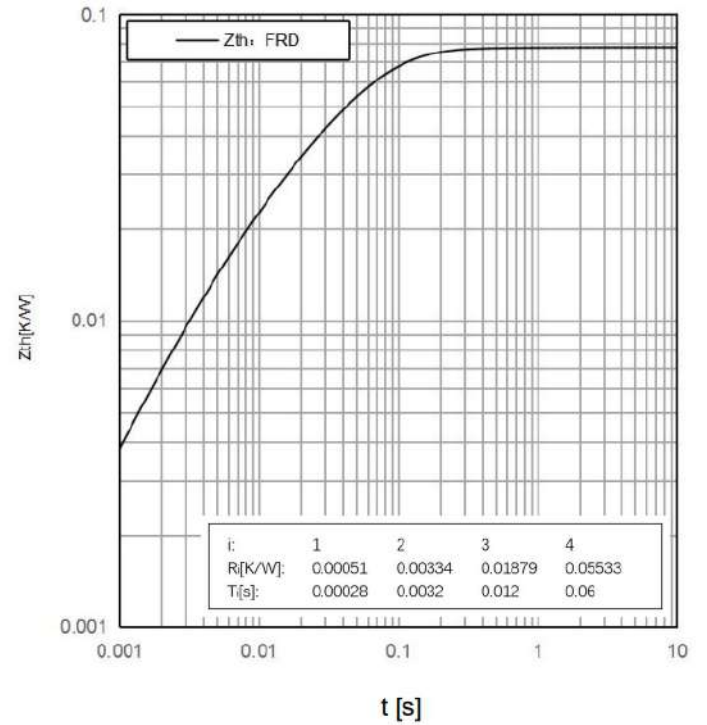

NTC Thermistor temperature characteristic
(typical)

$R = f(T)$

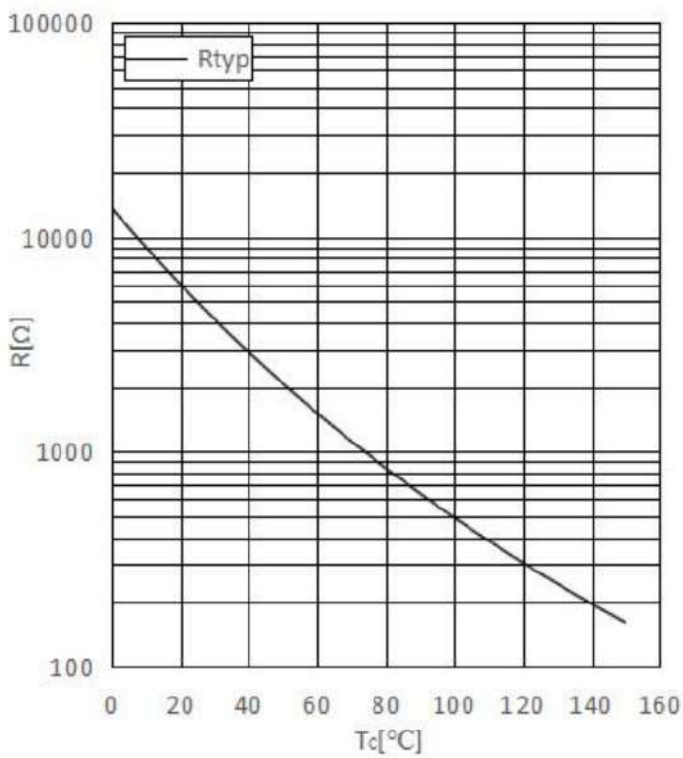

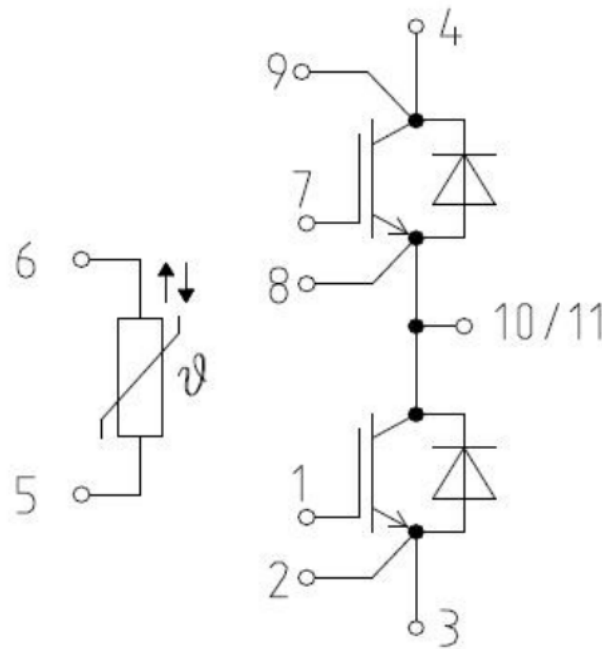
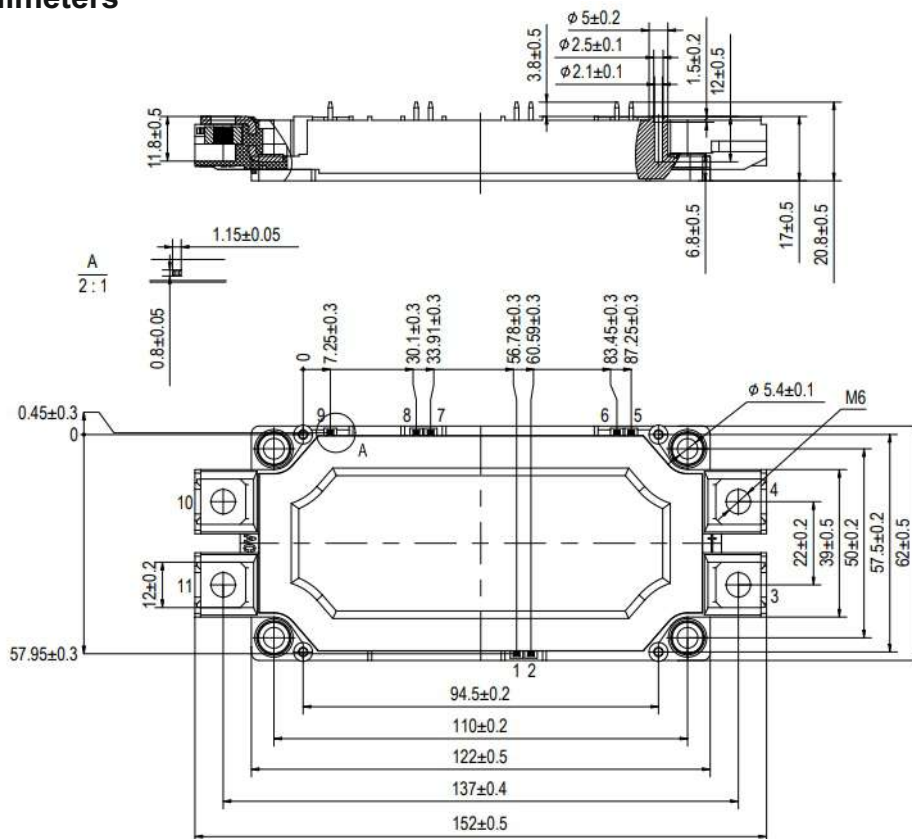
Internal Circuit

**Package Dimension/
Dimensions in Millimeters**

Terms and Conditions of Usage of Technicon products

The data contained in this product datasheet is exclusively intended for technically trained staff. You and your technical departments will have to evaluate the suitability of the product for the intended application and the completeness of the product data with respect to such application. This product data sheet is describing the characteristics of this product for which a warranty is granted. Any such warranty is granted exclusively pursuant to the terms and conditions of the supply agreement. Therefore, products must be tested for the respective application in advance. Application adjustments may be necessary.

The user of Technicon products is responsible for the safety of their applications embedding Technicon products and must take adequate safety measures to prevent the applications from causing physical injury, fire, or other problems if any of Technicon products become faulty. The user is responsible for ensuring that the application design is compliant with all applicable laws, regulations, norms, and standards.

Except as otherwise explicitly approved by Technicon in a written document signed by authorized representatives of Technicon, Technicon products may not be used in any applications where a failure of the product or any consequences of the use thereof can reasonably be expected to result in personal injury.

No representation or warranty is given and no liability is assumed with respect to the accuracy, completeness and/or use of any information herein, including without limitation, warranties of non-infringement of intellectual property rights of any third party. Technicon does not assume any liability arising out of the applications or use of any product; neither does it convey any license under its patent rights, copyrights, trade secrets, or other intellectual property rights, nor the rights of others.

Technicon makes no representation or warranty of non-infringement or alleged non-infringement of intellectual property rights of any third party which may arise from applications. This document supersedes and replaces all information previously supplied and may be superseded by updates. Technicon reserves the right to make changes.

For any questions or suggestions, please contact us at info@technicon.asia .