

C5 series package: 1200V 450A IGBT module

[Datasheet](#)

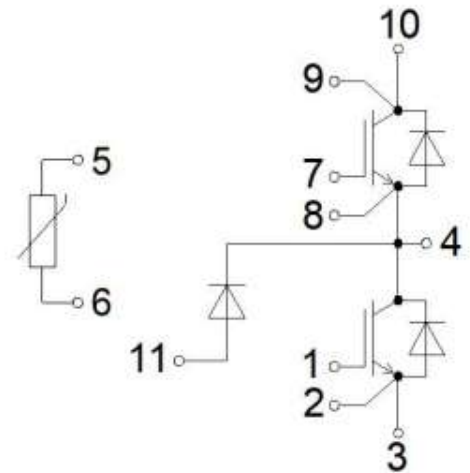

Equivalent
Circuit Schematic

Features:

- Trenchgate Gen.7 IGBT technology
- $V_{CE(sat)}$ with positive temperature coefficient
- High RBSOA capability
- Low static losses: $V_{CE(sat)} = 1,5V@25^{\circ}C$
- Low dynamic losses

Options:

- Pre-applied TIM (option +M01)
- Adoption for parallel connection (V_f selection)

Typical Applications:

- 3L NPC inverters
- Motor drives
- Energy Storage

**IGBT, Inverter / IGBT
Maximum Rated Values**

Collector-emitter Voltage	$T_{vj} = 25^{\circ}\text{C}$	V_{CES}	1200	V
Continuous DC Collector Current		I_{Cnom}	450	A
	$T_C = 100^{\circ}\text{C}, T_{vj\ max} \leq 175^{\circ}\text{C}$	I_C	500	A
Repetitive Peak Collector Current	$t_p T_{vj\ op}$	I_{CRM}	900	A
Total Power Dissipation	$T_C = 25^{\circ}\text{C}, T_{vj\ max} = 175^{\circ}\text{C}$	P_{tot}	2344	W
Gate-emitter Peak Voltage		V_{GES}	± 20	V

Characteristic Values

		min. typ. max.				
Collector-emitter Saturation Voltage ¹⁾	$I_C = 450\text{A}, V_{GE} = 15\text{V}$ $T_{vj} = 25^{\circ}\text{C}$ $T_{vj} = 150^{\circ}\text{C}$ $T_{vj} = 175^{\circ}\text{C}$	V_{CEsat}	1.40	1.50 1.76 1.84	1.70	V
Gate Threshold Voltage	$V_{CE} = V_{GE}, I_C = 24\text{mA}, T_{vj} = 25^{\circ}\text{C}$	V_{GEth}	5.0	6.0	7.0	V
Gate Charge	$V_{GE} = -10\text{V}/15\text{V}, V_{CE} = 600\text{V}$	Q_G	-	4.1	-	μC
Internal Gate Resistor	$T_{vj} = 25^{\circ}\text{C}$	R_{Gint}	-	1.05	-	Ω
Input Capacitance	$f = 100\text{kHz}, T_{vj} = 25^{\circ}\text{C}, V_{CE} = 25\text{V}, V_{GE} = 0\text{V}$	C_{ies}	-	106	-	nF
Output Capacitance	$f = 100\text{kHz}, T_{vj} = 25^{\circ}\text{C}, V_{CE} = 25\text{V}, V_{GE} = 0\text{V}$	C_{oes}	-	1.96	-	nF
Reverse Transfer Capacitance	$f = 100\text{kHz}, T_{vj} = 25^{\circ}\text{C}, V_{CE} = 25\text{V}, V_{GE} = 0\text{V}$	C_{res}	-	0.28	-	nF
Collector-emitter Cutoff Current	$V_{CE} = 1200\text{V}, V_{GE} = 0\text{V}, T_{vj} = 25^{\circ}\text{C}$	I_{CES}	-	-	100	μA
Gate-emitter Leakage Current	$V_{CE} = 0\text{V}, V_{GE} = 20\text{V}, T_{vj} = 25^{\circ}\text{C}$	I_{GES}	-	-	500	nA
Turn-on Delay Time, Inductive Load	$I_C = 450\text{A}, V_{CE} = 600\text{V}$ $V_{GE} = -8\text{V}/15\text{V}$ $R_{GON} = 0.5\Omega$ $T_{vj} = 25^{\circ}\text{C}$ $T_{vj} = 125^{\circ}\text{C}$ $T_{vj} = 150^{\circ}\text{C}$ $T_{vj} = 175^{\circ}\text{C}$	t_{don}	-	186 192 195 217	-	ns
Rise Time, Inductive Load	$I_C = 450\text{A}, V_{CE} = 600\text{V}$ $V_{GE} = -8\text{V}/15\text{V}$ $R_{GON} = 0.5\Omega$ $T_{vj} = 25^{\circ}\text{C}$ $T_{vj} = 125^{\circ}\text{C}$ $T_{vj} = 150^{\circ}\text{C}$ $T_{vj} = 175^{\circ}\text{C}$	t_r	-	54 64 67 85	-	ns
Turn-off Delay Time, Inductive Load	$I_C = 450\text{A}, V_{CE} = 600\text{V}$ $V_{GE} = -8\text{V}/15\text{V}$ $R_{GON} = 1.0\Omega$ $T_{vj} = 25^{\circ}\text{C}$ $T_{vj} = 125^{\circ}\text{C}$ $T_{vj} = 150^{\circ}\text{C}$ $T_{vj} = 175^{\circ}\text{C}$	t_{doff}	-	435 485 492 553	-	ns
Fall Time, Inductive Load	$I_C = 450\text{A}, V_{CE} = 600\text{V}$ $V_{GE} = -8\text{V}/15\text{V}$ $R_{Goff} = 1\Omega$ $T_{vj} = 25^{\circ}\text{C}$ $T_{vj} = 125^{\circ}\text{C}$ $T_{vj} = 150^{\circ}\text{C}$ $T_{vj} = 175^{\circ}\text{C}$	t_f	-	123 191 203 210	-	ns
Turn-on Energy Loss per Pulse	$I_C = 450\text{A}, V_{CE} = 600\text{V}, L_{\sigma} = 30\text{nH}$ $V_{GE} = -8\text{V}/15\text{V}, R_{gon} = 0.5\Omega$ $di/dt = 4200\text{A}/\mu\text{s} (T_{vj} = 175^{\circ}\text{C})$ $T_{vj} = 25^{\circ}\text{C}$ $T_{vj} = 125^{\circ}\text{C}$ $T_{vj} = 150^{\circ}\text{C}$ $T_{vj} = 175^{\circ}\text{C}$	E_{on}	-	18.4 27.5 31.2 35.0	-	mJ
Turn-off energy Loss per Pulse	$I_C = 450\text{A}, V_{CE} = 600\text{V}, L_{\sigma} = 30\text{nH}$ $V_{GE} = -8\text{V}/15\text{V}, R_{goff} = 1.0\Omega$ $du/dt = 6300\text{V}/\mu\text{s} (T_{vj} = 175^{\circ}\text{C})$ $T_{vj} = 25^{\circ}\text{C}$ $T_{vj} = 125^{\circ}\text{C}$ $T_{vj} = 150^{\circ}\text{C}$ $T_{vj} = 175^{\circ}\text{C}$	E_{off}	-	33.4 46.4 50.4 56.9	-	mJ

SC Data	V _{GE} = -8V/15V V _{CC} = 600V	t _p ≤ 10μs, T _{vj} = 25°C t _p ≤ 10μs, T _{vj} = 150°C t _p ≤ 10μs, T _{vj} = 175°C	I _{sc}	-	2700 2100 2000	-	A
Thermal Resistance, Junction to Case	Per IGBT / IGBT		R _{thJC}	-	0.064	-	K/W
Thermal Resistance, Case to Heatsink	Per IGBT / IGBT λ _{grease} = 1W/(m·K)		R _{thCH}	-	0.019	-	K/W
Temperature under Switching Conditions			T _{vj op}	-40		175	°C

Diode, Inverter Maximum Rated Values

Repetitive Peak Reverse Voltage	T _{vj} = 25°C	V _{RRM}	1200	V
Continuous DC Forward Current		I _{Fnom}	450	A
Repetitive Peak Forward Current	t _p T _{vj op}	I _{FRM}	900	A

Characteristic Values

			min. typ. max.				
Forward Voltage ¹⁾	I _F = 450A, V _{GE} = 0V	T _{vj} = 25°C T _{vj} = 150°C T _{vj} = 175°C	V _F	1.50	1.95 1.92 1.82	2.40	V
Peak Reverse Recovery Current	I _F = 450A, V _R = 600V -di _F /dt = 5600A/μs (T _{vj} = 175°C) V _{GE} = -8V	T _{vj} = 25°C T _{vj} = 125°C T _{vj} = 150°C T _{vj} = 175°C	I _{RM}	-	302 358 374 390	-	A
Recovery Charge	I _F = 450A, V _R = 600V -di _F /dt = 5600A/μs (T _{vj} = 175°C) V _{GE} = -8V	T _{vj} = 25°C T _{vj} = 125°C T _{vj} = 150°C T _{vj} = 175°C	Q _R	-	21.3 42.1 50.0 56.0	-	μC
Reverse Recovery Energy	I _F = 450A, V _R = 600V -di _F /dt = 5600A/μs (T _{vj} = 175°C) V _{GE} = -8V	T _{vj} = 25°C T _{vj} = 125°C T _{vj} = 150°C T _{vj} = 175°C	E _{rec}	-	11.3 22.5 27.7 33.0	-	mJ
Thermal Resistance, Junction to Case	Per FRD		R _{thJC}	-	0.092	-	K/W
Thermal Resistance, Case to Heatsink	Per FRD λ _{grease} = 1W/(m·K)		R _{thHC}	-	0.021	-	K/W
Temperature under Switching Conditions ²⁾			T _{vj op}	-40	-	175	°C

**Diode, 3-Level
Maximum Rated Values**

Repetitive Peak Reverse Voltage	$T_{vj} = 25^{\circ}\text{C}$	V_{RRM}	1200	V
Continuous DC Forward Current		I_{Fnom}	450	A
Repetitive Peak Forward Current	$T_{vj\ op}$	I_{FRM}	900	A

Characteristic Values

			min.	typ.	max.		
Forward Voltage ¹⁾	$I_F = 450\text{A}, V_{GE} = 0\text{V}$	$T_{vj} = 25^{\circ}\text{C}$ $T_{vj} = 150^{\circ}\text{C}$ $T_{vj} = 175^{\circ}\text{C}$	V_F	1.50	1.95 1.92 1.82	2.40	V
Peak Reverse Recovery Current	$I_F = 450\text{A}, V_R = 600\text{V}$ $-di_F/dt = 5600\text{A}/\mu\text{s} (T_{vj} = 175^{\circ}\text{C})$ $V_{GE} = -8\text{V}$	$T_{vj} = 25^{\circ}\text{C}$ $T_{vj} = 125^{\circ}\text{C}$ $T_{vj} = 150^{\circ}\text{C}$ $T_{vj} = 175^{\circ}\text{C}$	I_{RM}	-	302 358 374 390	-	A
Recovery Charge	$I_F = 450\text{A}, V_R = 600\text{V}$ $-di_F/dt = 5600\text{A}/\mu\text{s} (T_{vj} = 175^{\circ}\text{C})$ $V_{GE} = -8\text{V}$	$T_{vj} = 25^{\circ}\text{C}$ $T_{vj} = 125^{\circ}\text{C}$ $T_{vj} = 150^{\circ}\text{C}$ $T_{vj} = 175^{\circ}\text{C}$	Q_R	-	21.3 42.1 50.0 56.0	-	μC
Reverse Recovery Energy	$I_F = 450\text{A}, V_R = 600\text{V}$ $-di_F/dt = 5600\text{A}/\mu\text{s} (T_{vj} = 175^{\circ}\text{C})$ $V_{GE} = -8\text{V}$	$T_{vj} = 25^{\circ}\text{C}$ $T_{vj} = 125^{\circ}\text{C}$ $T_{vj} = 150^{\circ}\text{C}$ $T_{vj} = 175^{\circ}\text{C}$	E_{rec}	-	11.3 22.5 27.7 33.0	-	mJ
Thermal Resistance, Junction to Case	Per FRD		R_{thJC}	-	0.092	-	K/W
Thermal Resistance, Case to Heatsink	Per FRD $\lambda_{grease} = 1\text{W}/(\text{m}\cdot\text{K})$		R_{thHC}	-	0.021	-	K/W
Temperature under Switching Conditions ²⁾			$T_{vj\ op}$	-40	-	175	$^{\circ}\text{C}$

**NTC-Thermistor / NTC
Maximum Rated Values**

			min.	typ.	max.	
Rated Resistance	$T_{NTC} = 25^{\circ}\text{C}$	R_{25}	-	5	-	K Ω
Deviation of R100 R100	$T_{NTC} = 100^{\circ}\text{C}, R_{100} = 491\Omega$	$\Delta R/R$	-5	-	5	%
Power Dissipation	$T_{NTC} = 25^{\circ}\text{C}$	P_{25}	-	-	20	mW
B-Value	$R_2 = R_{25} \exp[B_{25/50}(1/T_2 - 1/(298.15\text{K}))]$	$B_{25/50}$	-	3375	-	K
	$R_2 = R_{25} \exp[B_{25/80}(1/T_2 - 1/(298.15\text{K}))]$	$B_{25/80}$	-	3425	-	K
	$R_2 = R_{25} \exp[B_{25/100}(1/T_2 - 1/(298.15\text{K}))]$	$B_{25/100}$	-	3443	-	K

1) Terminal impedance is not included.

2) $T_{vj\ op} > 150^{\circ}\text{C}$ is allowed for operation at overload conditions.
 $T_{vj\ op} > 150^{\circ}\text{C}$.

Module

Isolation Test Voltage	RMS, f=50Hz	V _{ISOL}	3.0	kV
Isolation Test Voltage of NTC NTC	RMS, f=50Hz	V _{ISOL (NTC)}	3.0	kV
Material of Module Baseplate			Cu	
Internal Isolation			ZTA	
Creepage Distance	Terminal to heatsink, min Terminal to terminal, min		14.7 15.1	mm
Clearance	Terminal to heatsink, min Terminal to terminal, min		9.6 12.5	mm
Comparative Tracking Index		CTI	>200	

min. typ. max.

Stray Inductance Module		L _{sCE}	–	20	–	nH
Module Lead Resistance, Terminals-Chip	T _C = 25°C, Per Switch	R _{CC'+EE'}	–	0.8	–	mΩ
Thermal Resistance, Case to Heatsink	including thermal coupling, T _s underneath module (λgrease=0.81 W/(m*K))	R _{thCH}	–	0.014	–	K/W
Storage Temperature		T _{stg}	-40	–	125	°C
Mounting Torque for Module Mounting	Screw M5 / M5	M	4.0	–	6.0	Nm
Mounting Torque for Terminal Mounting	Screw M6 / M6	M	4.0	–	6.0	Nm
Weight		G	–	345	–	g

Circuit Diagram

Output characteristic IGBT, Inverter (typical), IGBT
 $I_c = f(V_{CE})$, $V_{GE} = 15V$

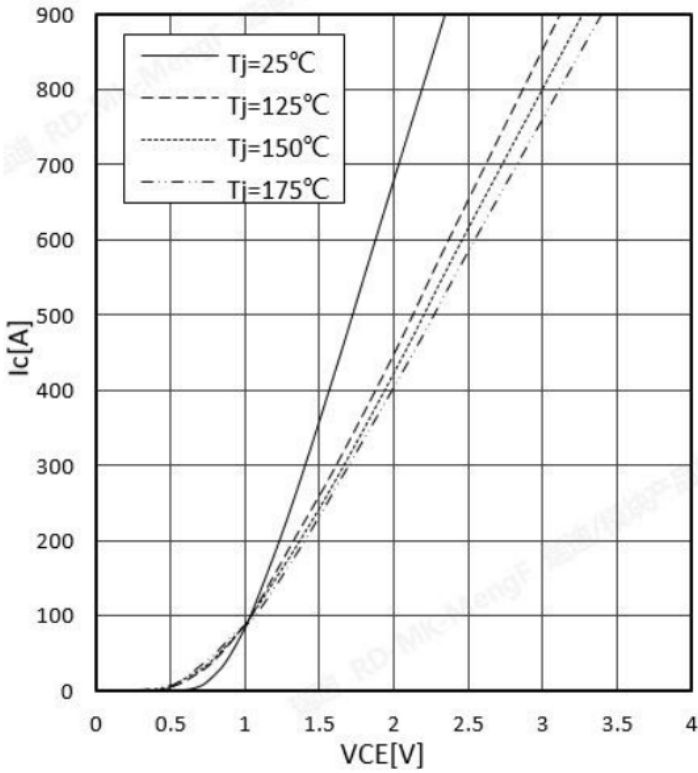

Output characteristic IGBT, Inverter (typical), IGBT
 $I_c = f(V_{CE})$, $T_{vj} = 175^\circ C$

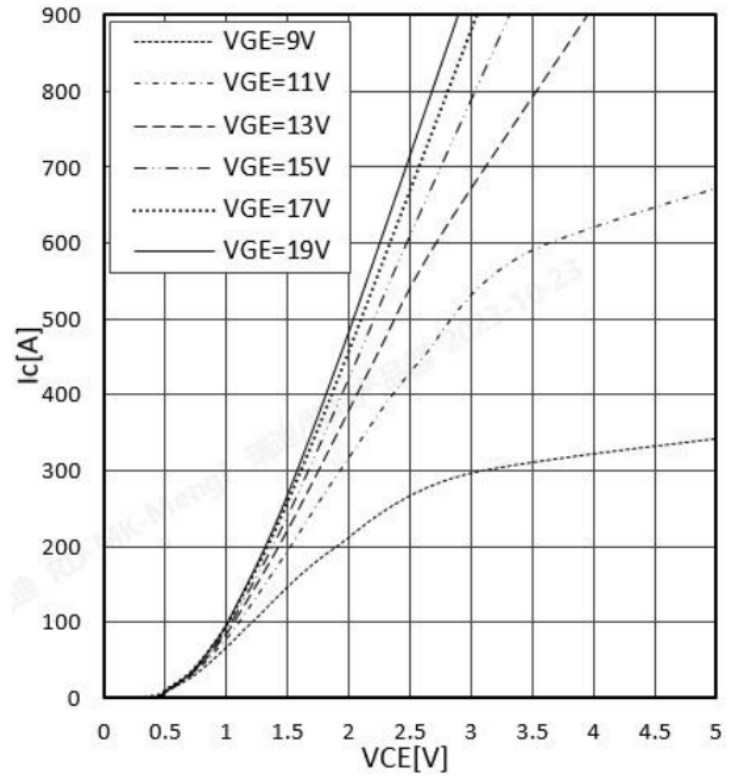

Transfer characteristic IGBT, Inverter (typical), IGBT
 $I_c = f(V_{GE})$, $V_{CE} = 20V$

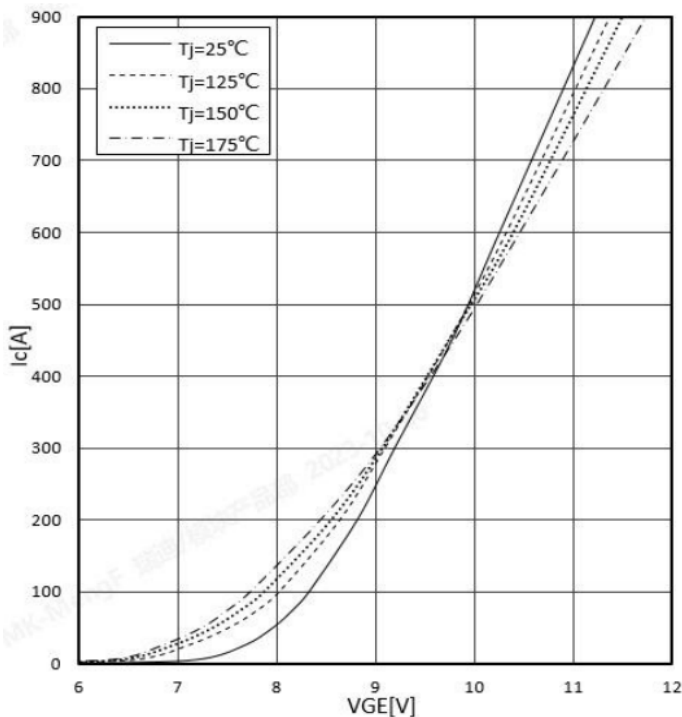

Switching losses IGBT, Inverter (Typical), IGBT

$E_{on} = f(I_c)$, $E_{off} = f(I_c)$
 $V_{GE} = +15V/-8V$, $R_{Gon} = 0.5\Omega$, $R_{Goff} = 1\Omega$, $V_{CC} = 600V$

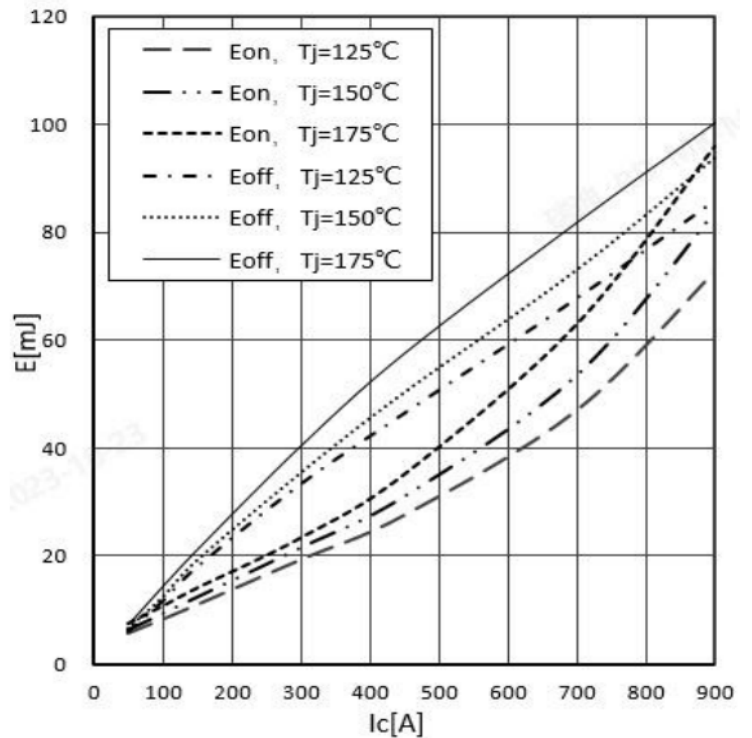

Switching time IGBT, Inverter (typical), IGBT

$t = f(I_c)$

$R_{Goff} = 1\Omega, R_{gon} = 0.5\Omega, V_{GE} = +15V/-8V, V_{CE} = 600V, T_{vj} = 175^\circ C$

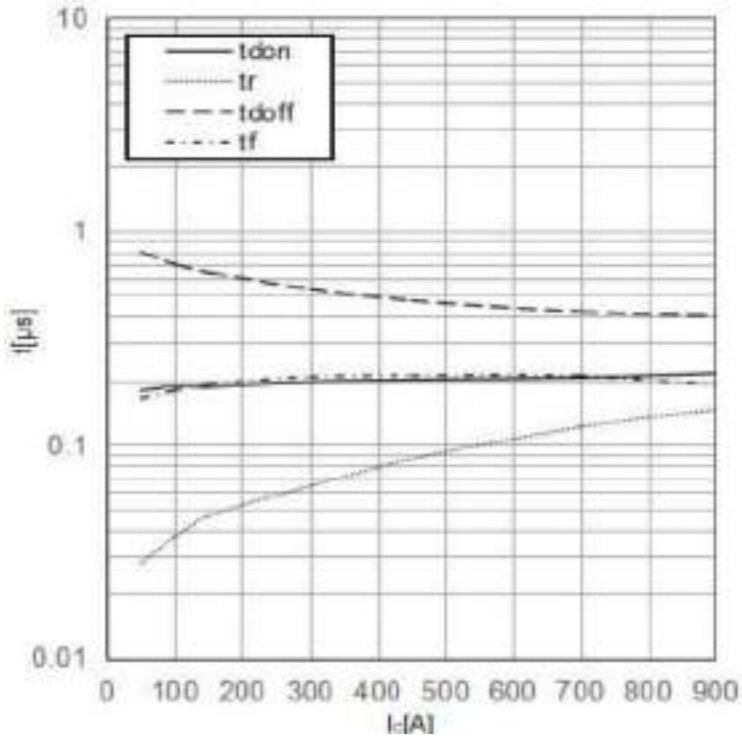

Switching time IGBT, Inverter (typical), IGBT

$t = f(R_G)$

$V_{GE} = +15V/-8V, I_c = 450A, V_{CE} = 600V, T_{vj} = 175^\circ C$

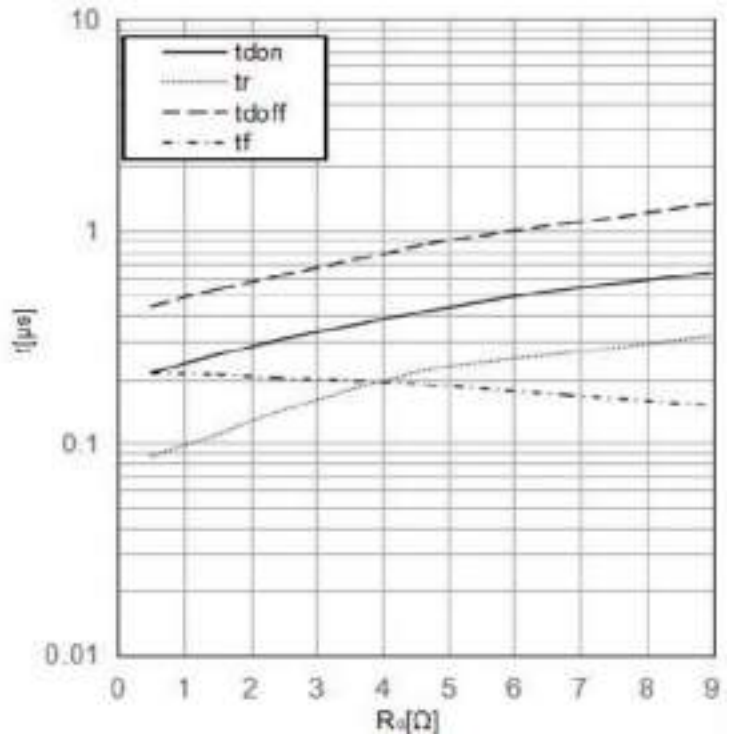

Capacitance characteristic IGBT, Inverter, IGBT

$C = f(V_{CE})$

$f = 100kHz, V_{GE} = 0V, T_{vj} = 25^\circ C$

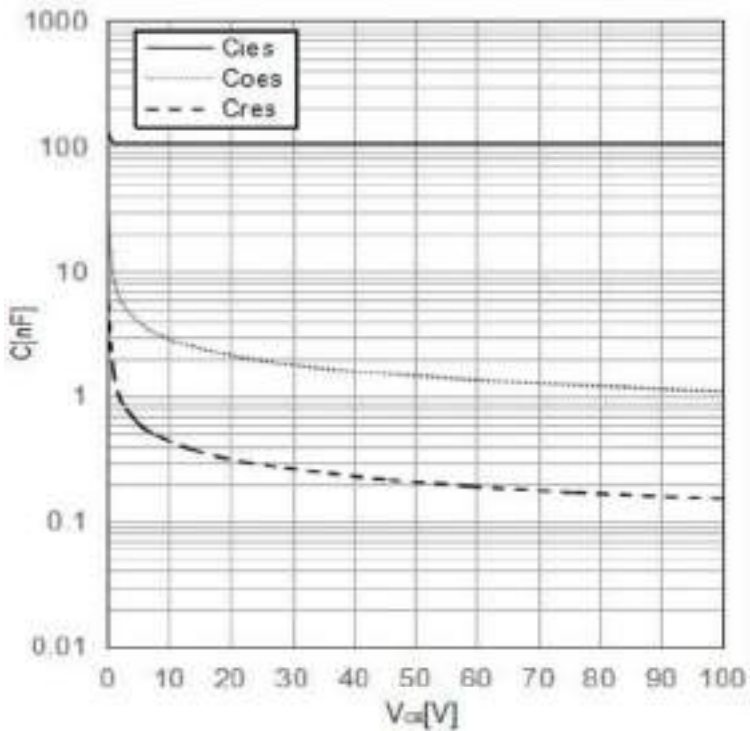

Gate Charge characteristic IGBT, Inverter, IGBT

$V_{GE} = f(Q_G)$

$I_c = 450A, T_{vj} = 25^\circ C$

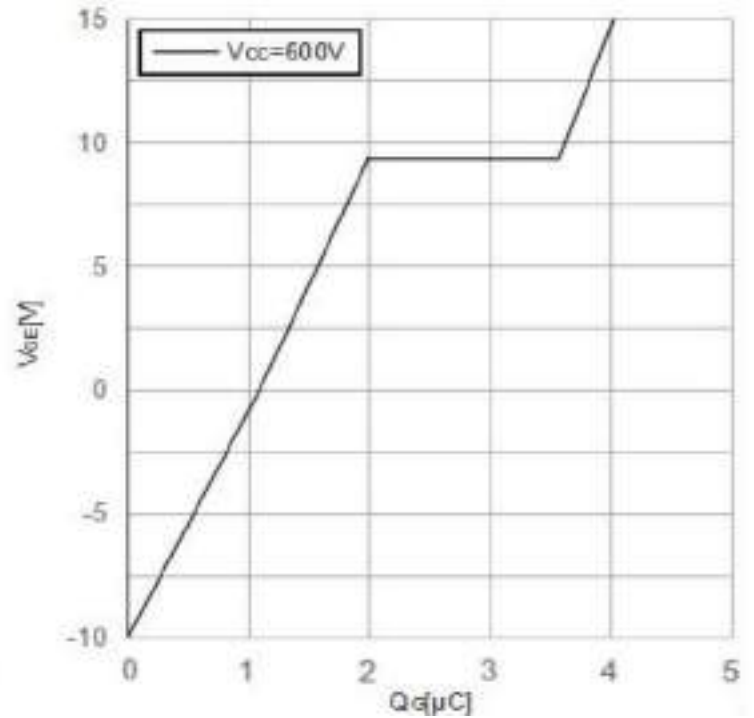

Switching losses IGBT, Inverter (Typical), IGBT
 $E_{on} = f(R_g)1\Omega$, $E_{off} = f(R_g)$,
 $V_{GE} = +15V/-8V$, $I_c = 450A$, $V_{CE} = 600V$

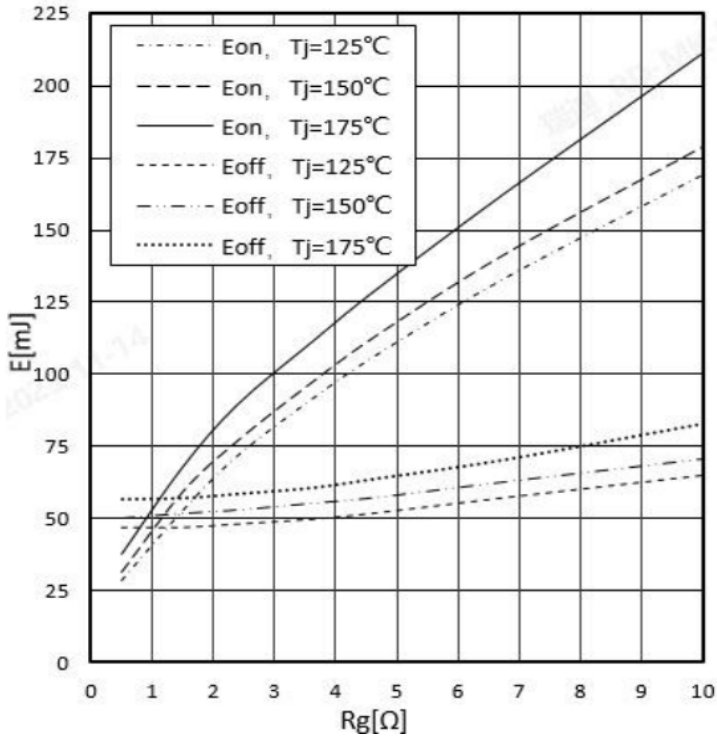

Transient thermal impedance IGBT, Inerter, IGBT
 $E_{thjc} = f(t)$

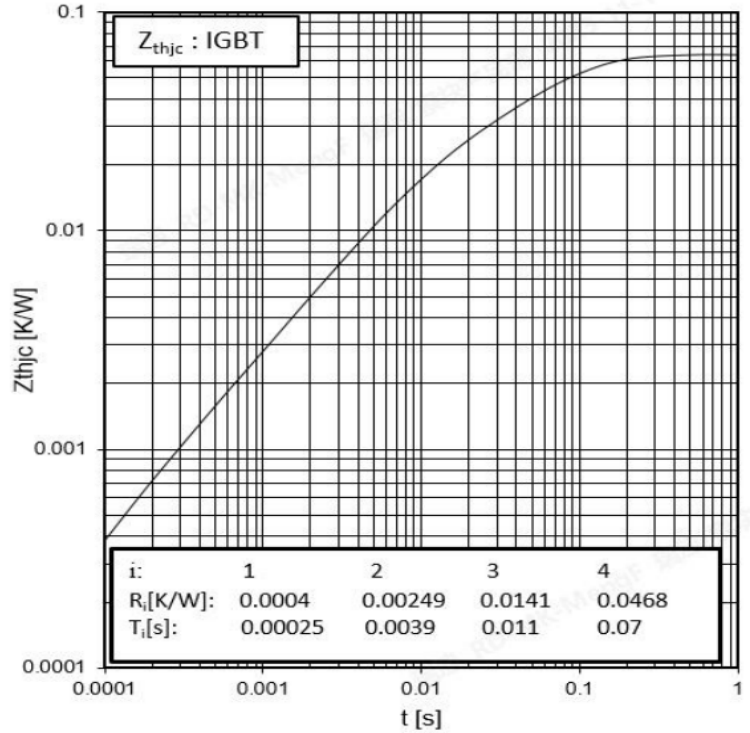

Reverse bias safe operating area IGBT, Inverter (RBSOA)
 IGBT (RBSOA)
 $I_c = f(V_{CE})$
 $V_{GE} = +15V/-8V$, $R_{goff} = 1\Omega$, $T_{vj} = 175^\circ C$

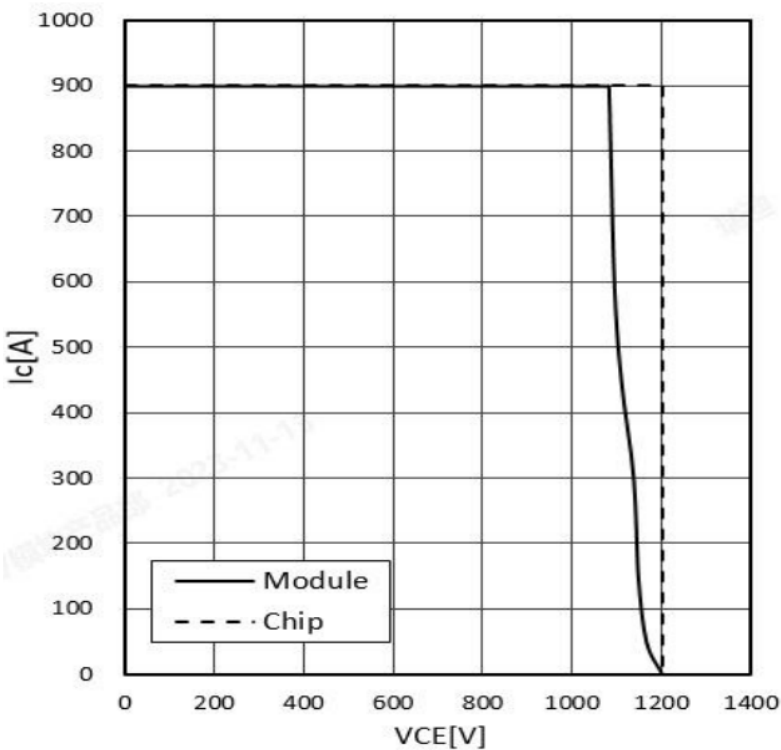

Forward characteristic of Diode, Inverter (typical)
 $I_F = f(V_F)$

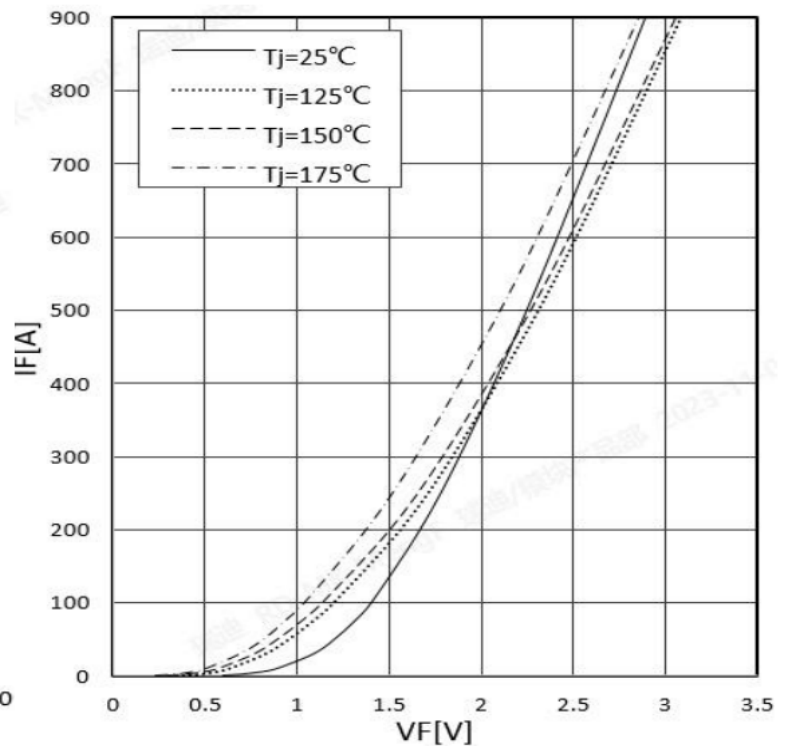

Switching losses Diode, Inverter (typical)
 $E_{rec} = f(I_F)$, $R_{gon} = 0.5\Omega$, $V_{CE} = 600V$

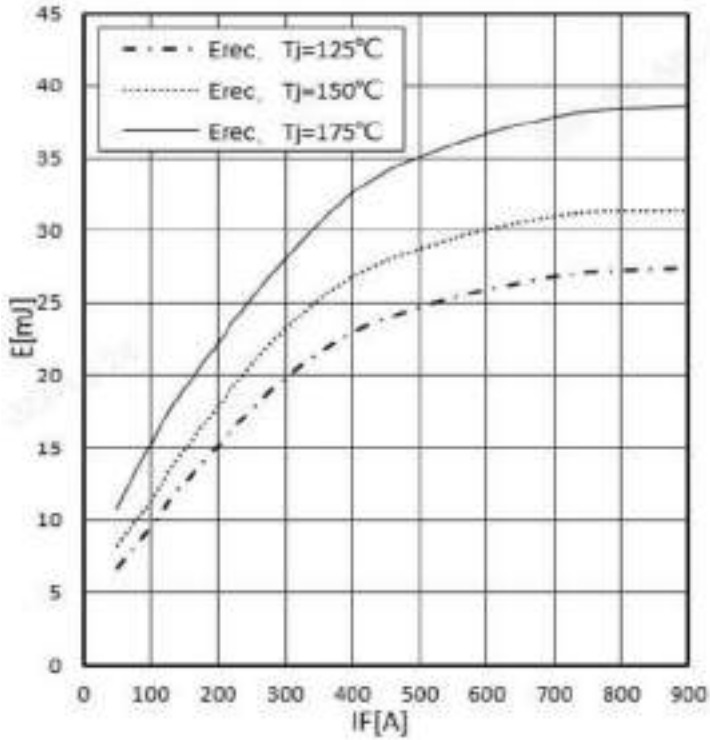

Switching losses Diode, Inverter (typical)
 $E_{rec} = f(R_g)$, $I_F = 450A$, $V_{CE} = 600V$

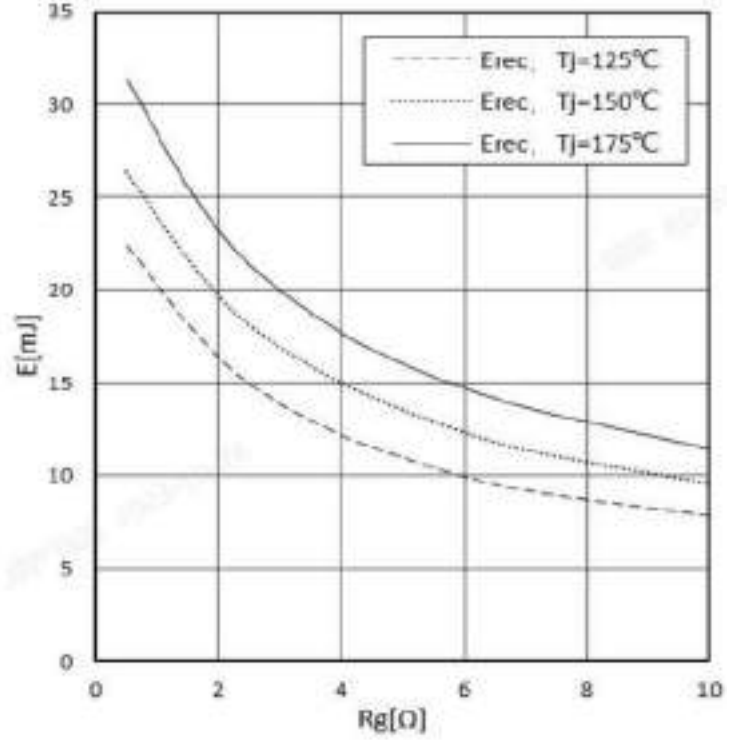

Transient thermal impedance Diode, Inverter
 $Z_{thJC} = f(t)$

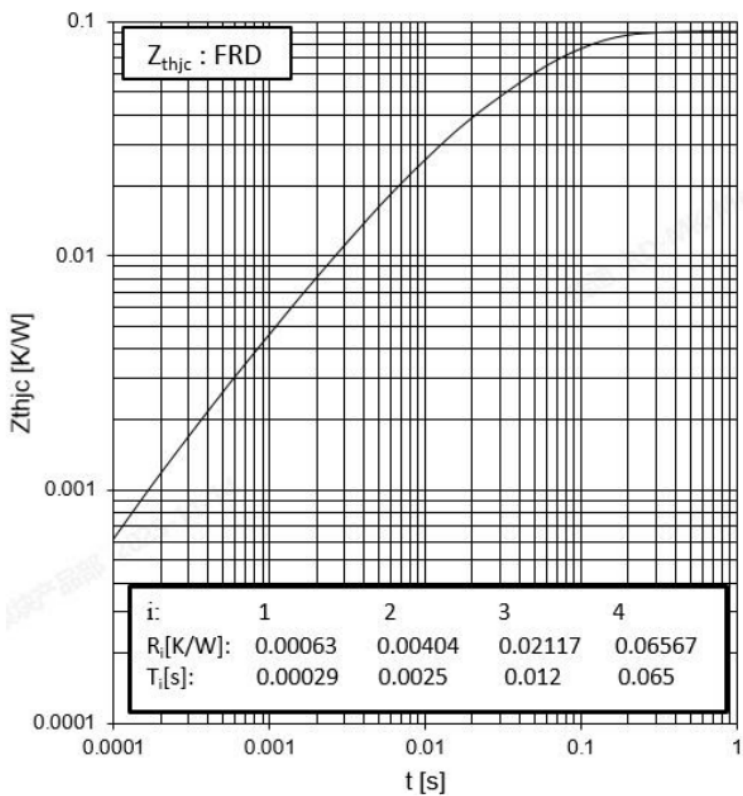

Forward characteristic of Diode, 3-Level (typical)
 $I_F = f(V_f)$

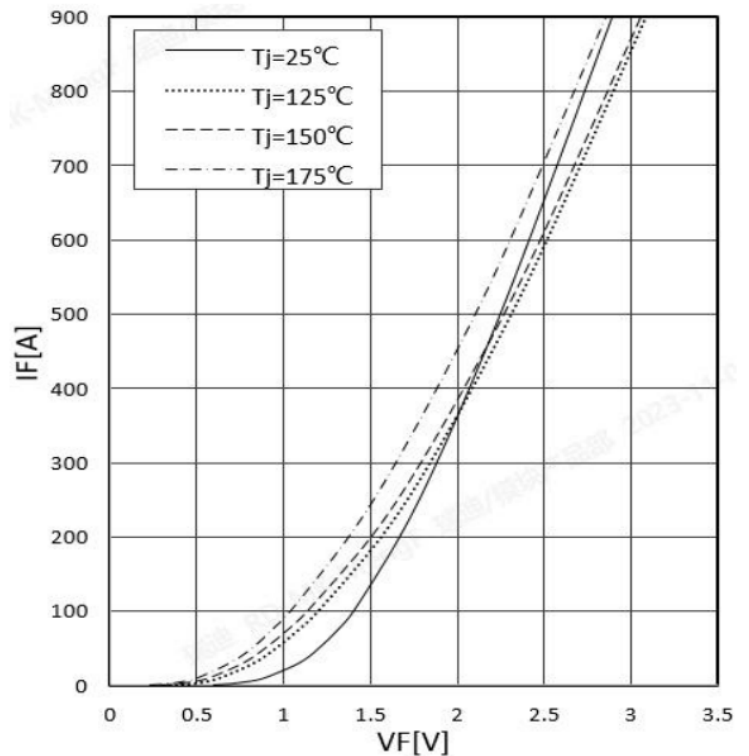

NTC-Thermistor-temperature characteristic (typical)
 $R = f(t)$

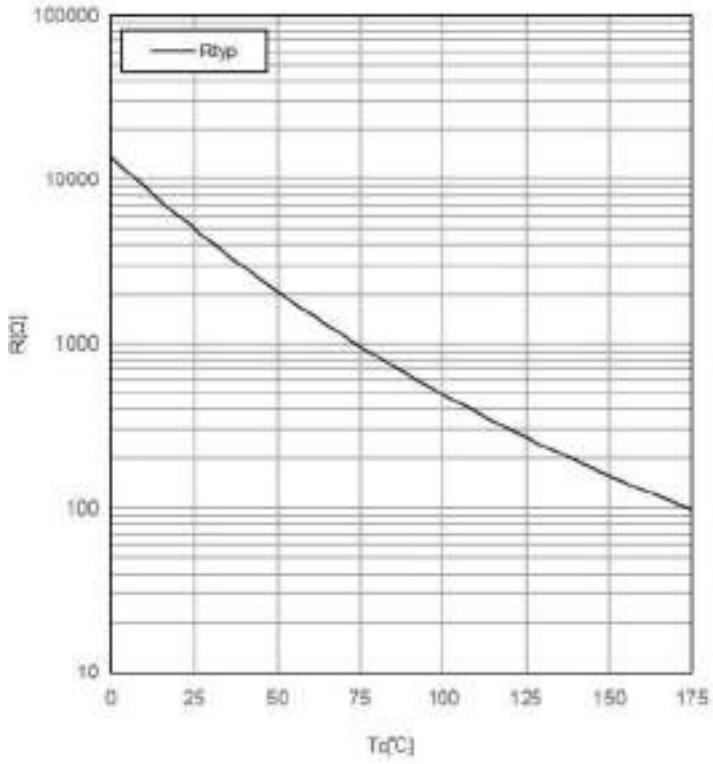

Terms and Conditions of Usage of Technicon products

The data contained in this product datasheet is exclusively intended for technically trained staff. You and your technical departments will have to evaluate the suitability of the product for the intended application and the completeness of the product data with respect to such application. This product data sheet is describing the characteristics of this product for which a warranty is granted. Any such warranty is granted exclusively pursuant to the terms and conditions of the supply agreement. Therefore, products must be tested for the respective application in advance. Application adjustments may be necessary.

The user of Technicon products is responsible for the safety of their applications embedding Technicon products and must take adequate safety measures to prevent the applications from causing physical injury, fire, or other problems if any of Technicon products become faulty. The user is responsible for ensuring that the application design is compliant with all applicable laws, regulations, norms, and standards.

Except as otherwise explicitly approved by Technicon in a written document signed by authorized representatives of Technicon, Technicon products may not be used in any applications where a failure of the product or any consequences of the use thereof can reasonably be expected to result in personal injury.

No representation or warranty is given and no liability is assumed with respect to the accuracy, completeness and/or use of any information herein, including without limitation, warranties of non-infringement of intellectual property rights of any third party. Technicon does not assume any liability arising out of the applications or use of any product; neither does it convey any license under its patent rights, copyrights, trade secrets, or other intellectual property rights, nor the rights of others.

Technicon makes no representation or warranty of non-infringement or alleged non-infringement of intellectual property rights of any third party which may arise from applications. This document supersedes and replaces all information previously supplied and may be superseded by updates. Technicon reserves the right to make changes.

For any questions or suggestions, please contact us at info@technicon.asia.